



General Certificate of Secondary Education
2024

Centre Number

--	--	--	--	--

Candidate Number

--	--	--	--

Physics

Unit 2

Foundation Tier

MV18

[GPY21]

TUESDAY 18 JUNE, MORNING

Time

1 hour 15 minutes, plus your additional time allowance.

Instructions to Candidates

Write your Centre Number and Candidate Number in the spaces provided at the top of this page.

You must answer the questions in the spaces provided.

Do not write on blank pages.

Complete in black ink only.

Answer **all** questions.

Information for Candidates

The total mark for this paper is 80.

Figures in brackets printed at the end of each question indicate the marks awarded to each question or part question.

Quality of written communication will be assessed in

Question **1(d)**.

1 (a) Waves can be classified as either transverse or longitudinal.

(i) Describe the difference between these two types of wave in terms of the motion of the particles of the medium through which the waves are moving.
[3 marks]

(ii) State an example of each type of wave. [2 marks]

Transverse

Longitudinal

(b) A wave can be represented by the graph shown below.

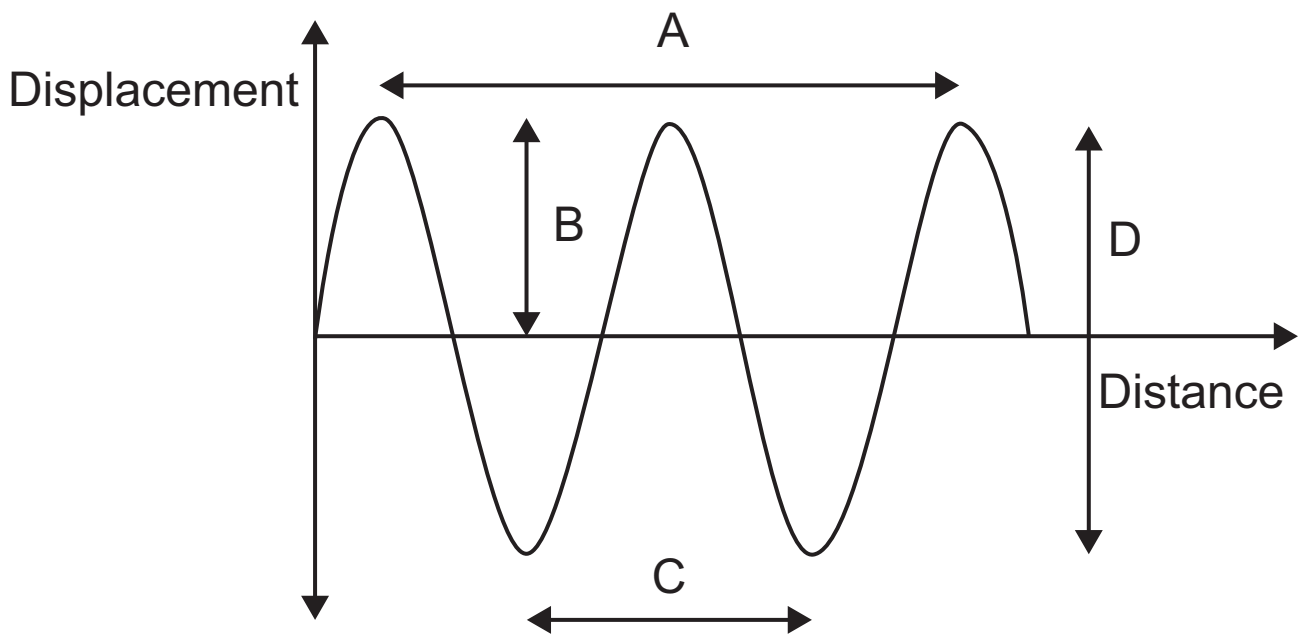

(i) Which letter represents the wavelength of the wave?
[1 mark]

(ii) Which letter represents the amplitude of the wave?
[1 mark]

(iii) The frequency of the wave is 12 Hz. What does this mean? [2 marks]

(c) The diagram below shows what happens to water waves when they move from deep water to shallow water.

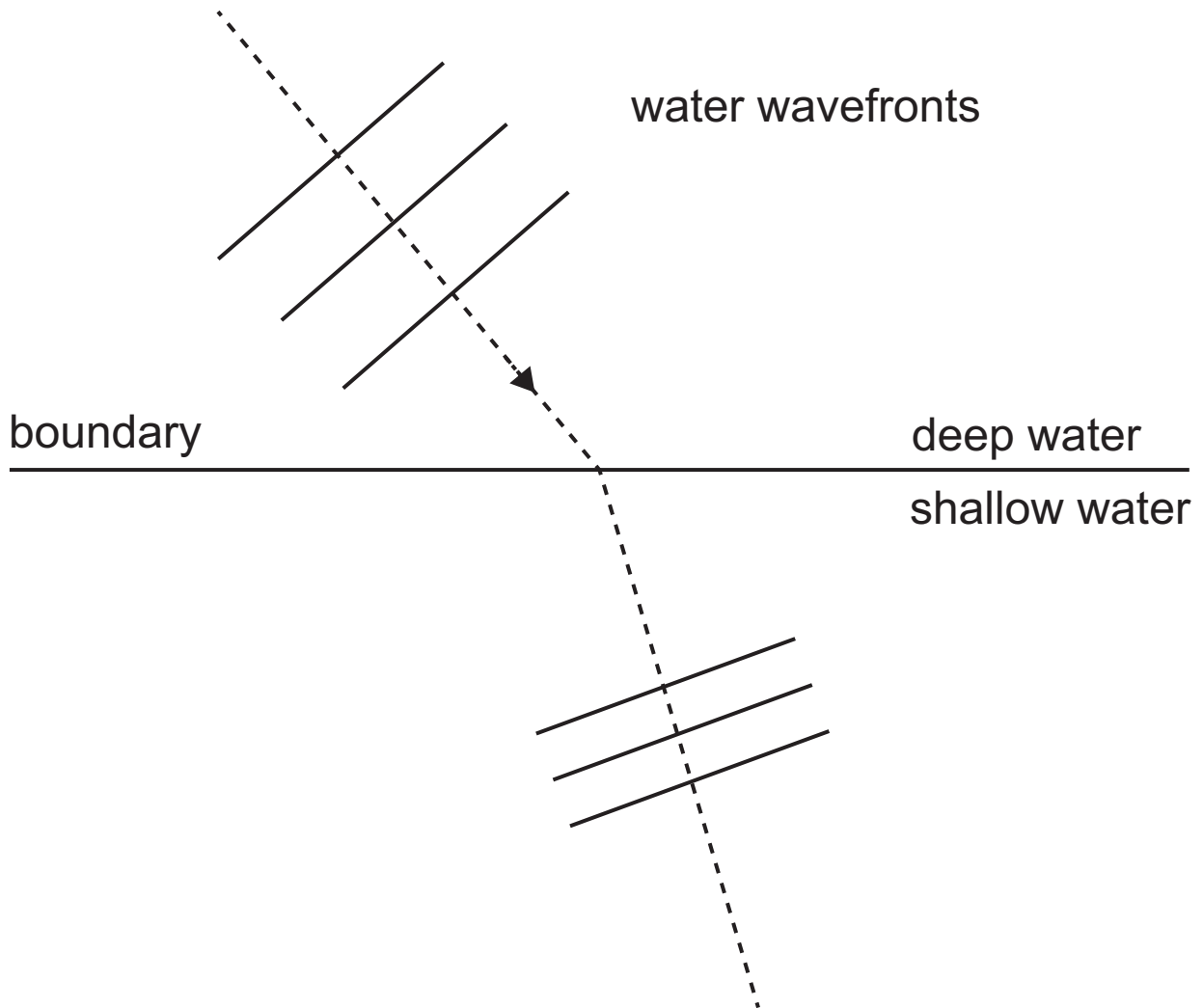

(i) This effect is called refraction.
Explain what causes this effect. [1 mark]

(ii) What observation from the diagram supports your answer? [1 mark]

(iii) The diagram below shows water waves approaching a solid barrier. The water waves are reflected by this solid barrier. Carefully complete the diagram, by drawing three wavefronts, showing what happens after the waves strike the barrier. [3 marks]

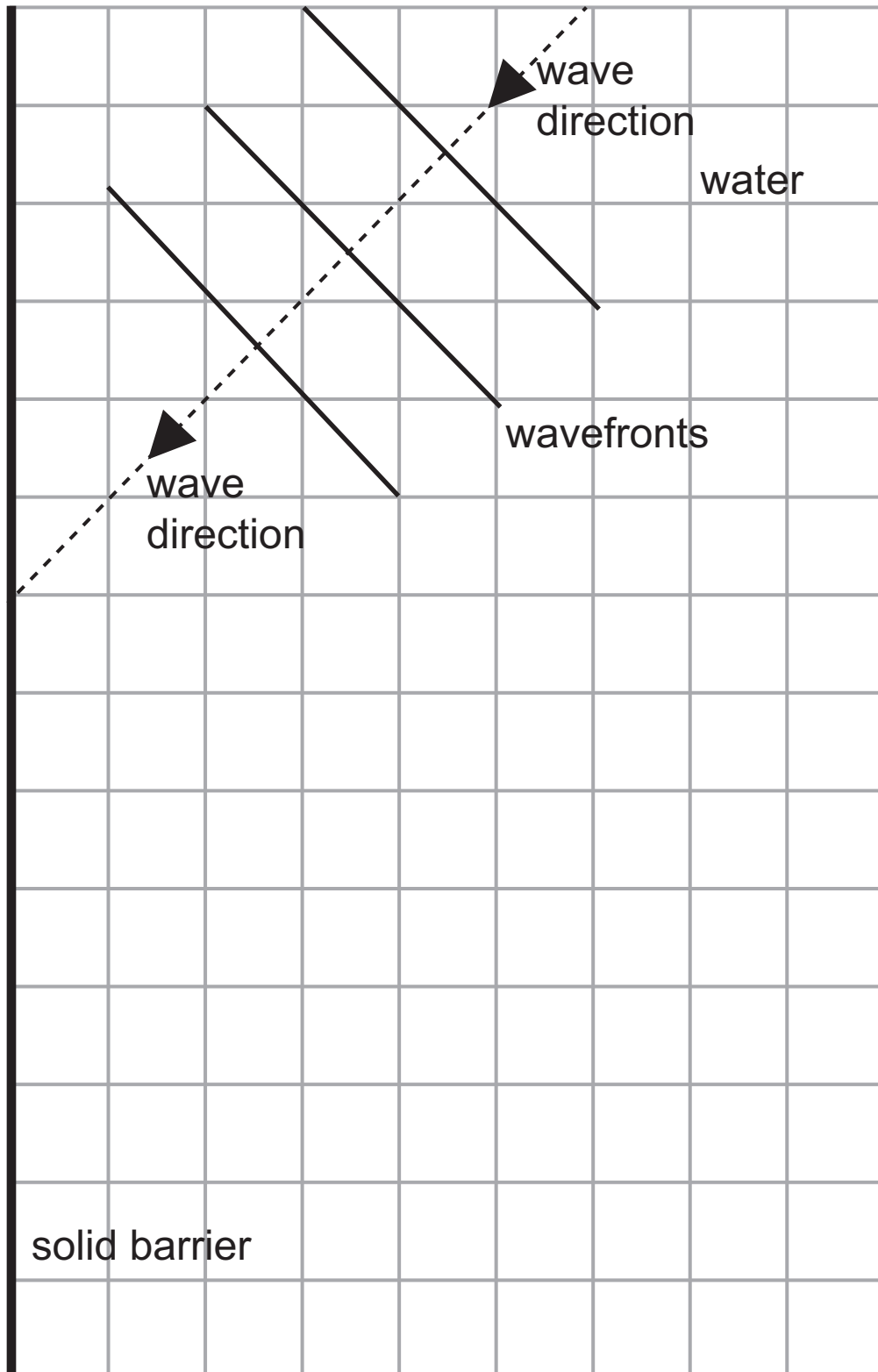

(d) Radar uses pulses of electromagnetic waves in the form of microwaves to calculate the distance to an aircraft. Describe, in detail, how this process is carried out.

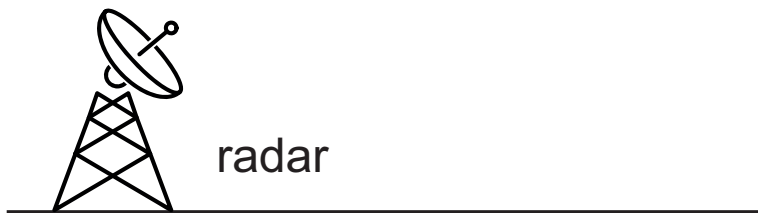
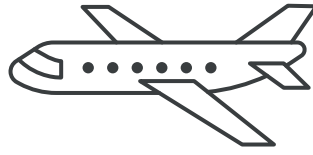

In your answer you should explain the following points:

- why microwaves are used rather than sound waves;
- what happens to the microwaves when they reach the aircraft;
- why the microwaves are emitted as a short pulse rather than continuously;
- what measurement is made;
- what property of the microwaves is needed for the calculation of the distance to the aircraft;
- what calculation is carried out to determine the distance to the aircraft.

In this question you will be assessed on your written communication skills including the use of specialist scientific terms.

Write your answers in the spaces below and on page 8.
[6 marks]

Microwaves, not sound waves, are used

What happens at the aircraft?

What is the reason for short pulses?

Measurement made

Property of microwaves needed

Calculation to determine distance

Blank Page

(Questions continue overleaf)

2 (a) A student observes an image in a plane mirror.

(i) Which of the following properties describe this image? [3 marks]

Tick (✓) the appropriate boxes to indicate your answers.

Diminished

Enlarged

Erect

Upside down

Real

Same size as object

Virtual

A child's toy car is placed 25 cm in front of a plane mirror.

The child moves the car a **further 40 cm away** from the mirror.

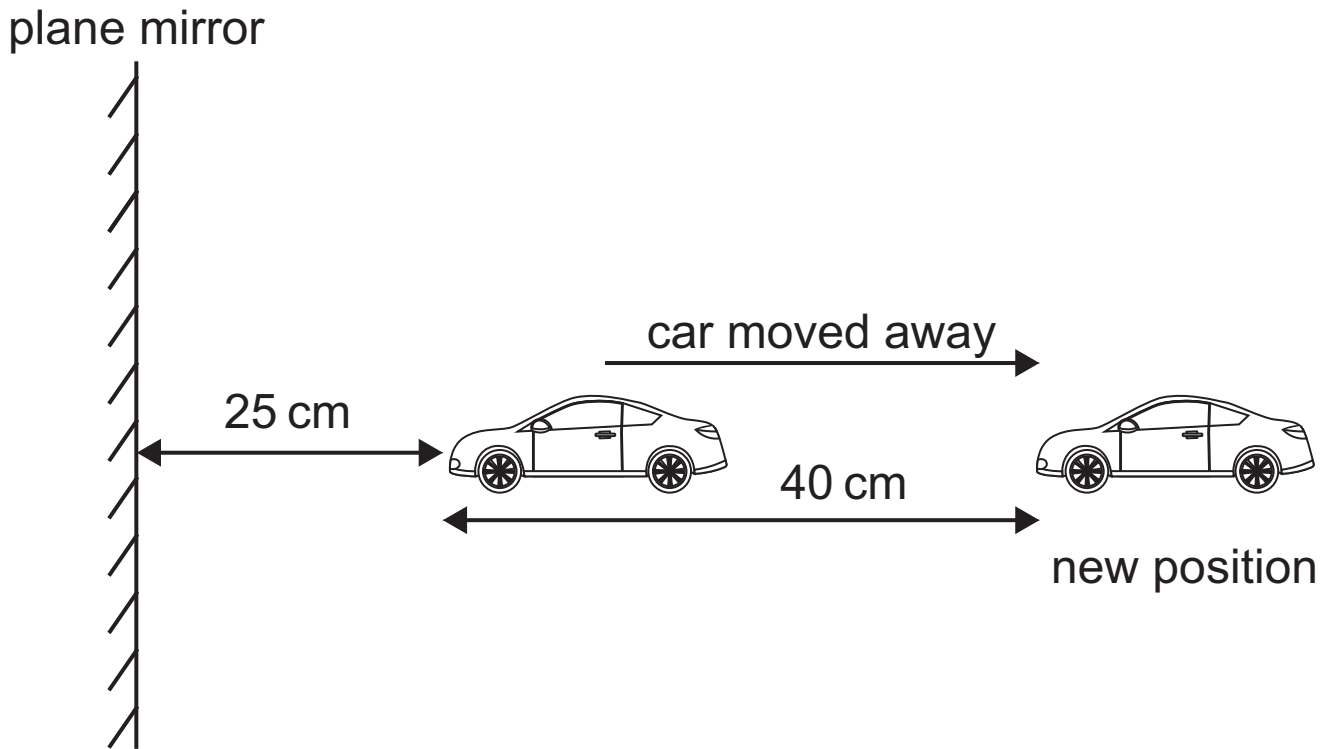

- (ii) Calculate the distance between the toy car and its image in the plane mirror after the toy car has been moved to its new position. [2 marks]

Distance between
toy car and its image = _____ cm

(b) The diagram shows a ray of light incident on a glass block.

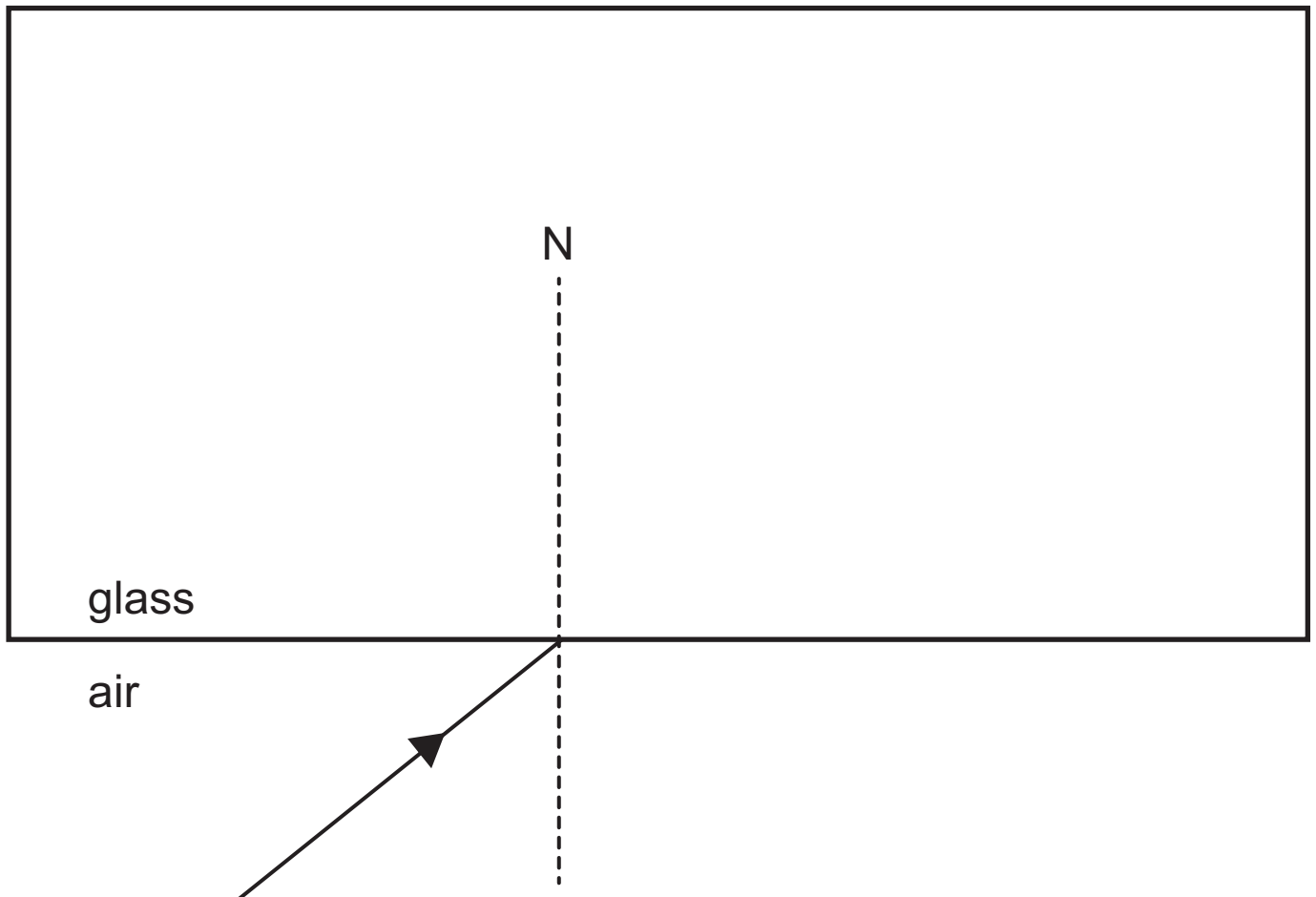

(i) What name is given to the dotted line marked N?
[1 mark]

(ii) Show clearly on the diagram the angle of incidence, labelling it with a letter **i**. [1 mark]

(iii) Draw the refracted ray in the glass. [2 marks]

(iv) In what way, if at all, does the angle of refraction in the glass change when the angle of incidence in the air increases?

Indicate your answer by drawing a circle around one of the phrases below. [1 mark]

Decreases

Does not change

Increases

(c) When white light travels from the air into a triangular glass prism it splits up into different coloured rays.

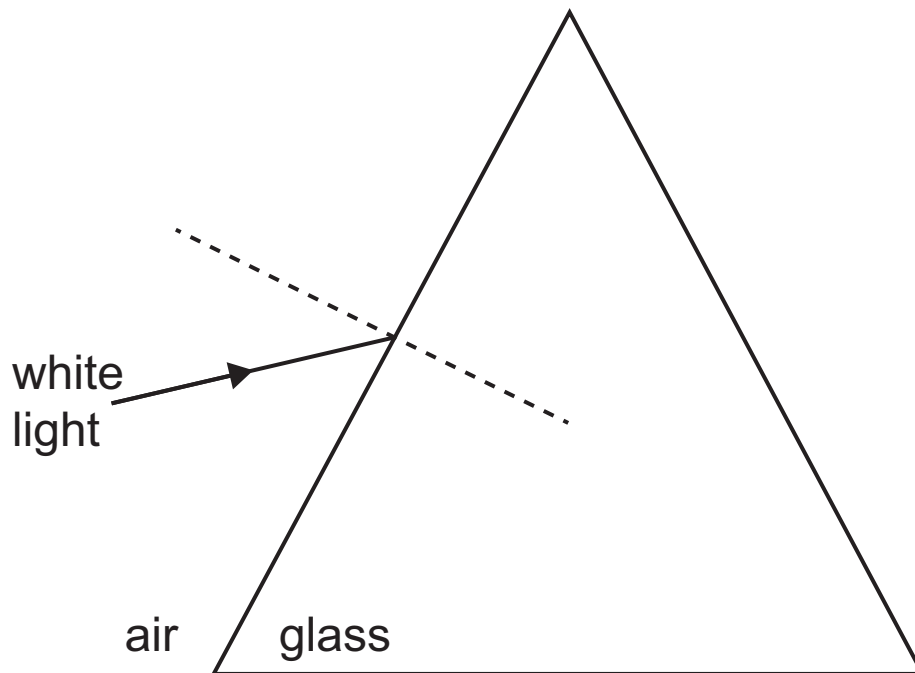

(i) What name is given to this effect? [1 mark]

(ii) Complete the diagram above to show the path of the red and violet rays through the prism and as they leave it. Label each ray. [3 marks]

(iii) What causes the splitting of white light into different colours of light? [1 mark]

(d) (i) State what is meant by the focal length of a converging lens. [1 mark]

The diagram below shows two parallel light rays entering a lens.

(ii) Complete the diagram to show what happens to the two light rays as they pass through the lens. F is the principal focus. [2 marks]

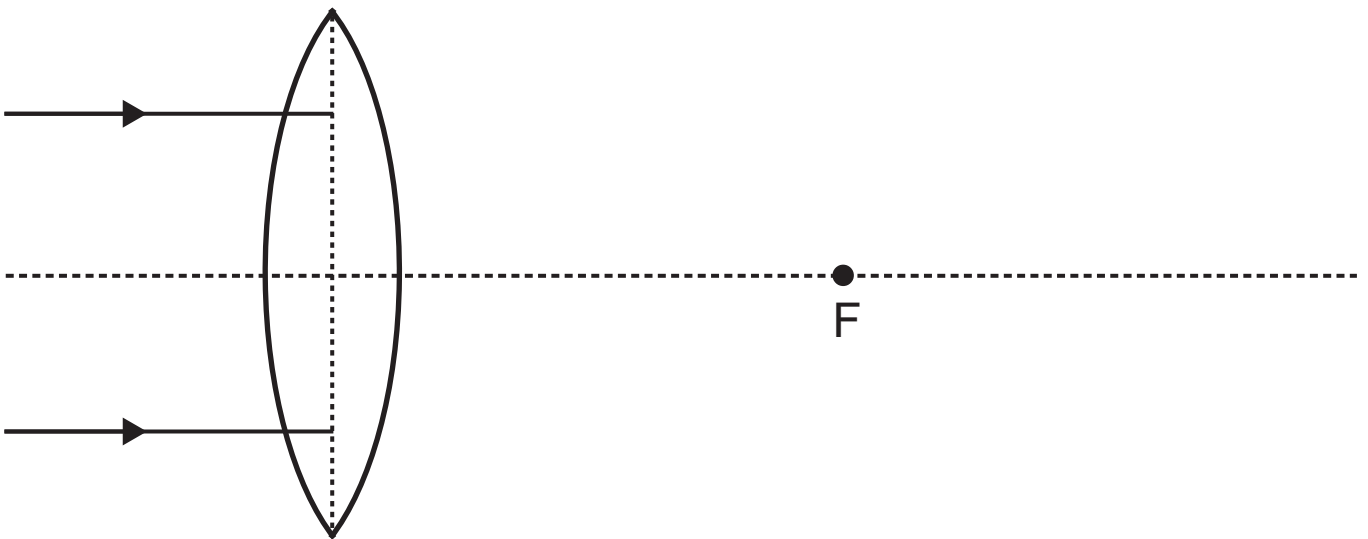

A student is asked to carry out an experiment to measure the focal length of a converging lens using a distant object.

(iii) Other than the lens itself and the distant object, state **two** pieces of apparatus needed to find the focal length. [2 marks]

1. _____

2. _____

- 3 (a) (i) The diagram below shows a fused three pin plug. In the boxes provided name the wires and their colour. [3 marks]

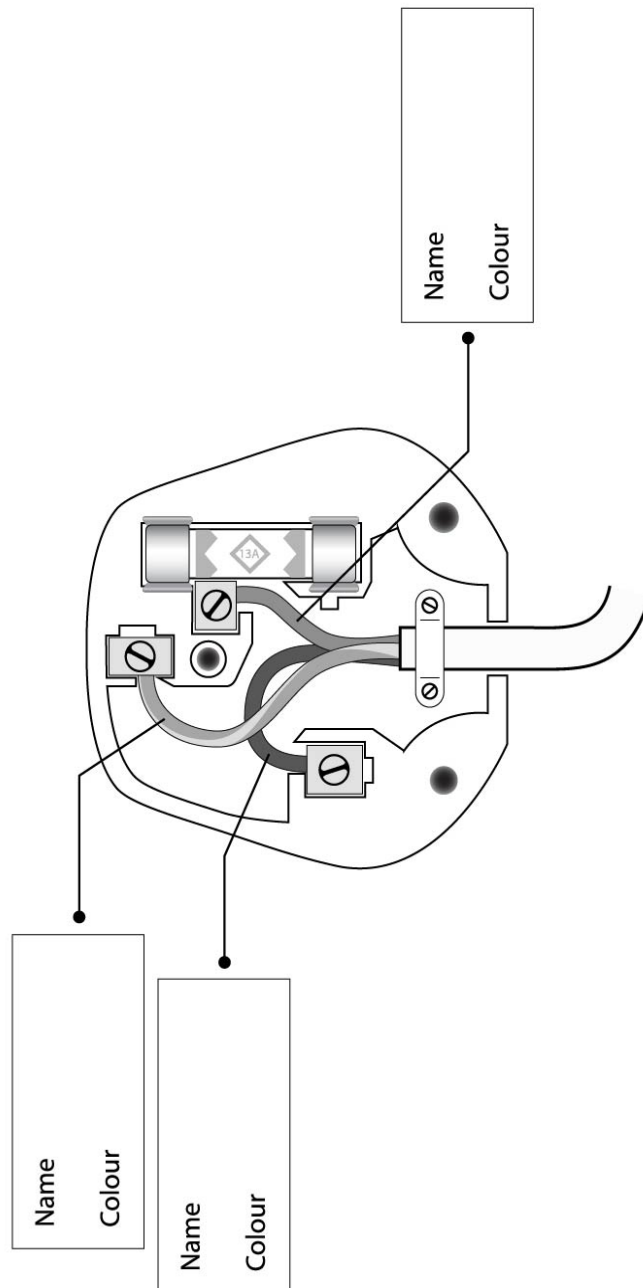

- (ii) On the diagram above mark with an arrow and label the fuse. [1 mark]

Two way switches are common in homes so that a light can be switched on or off from different positions, for example at the top or bottom of a staircase. The diagram below shows a circuit using a two way switch circuit.

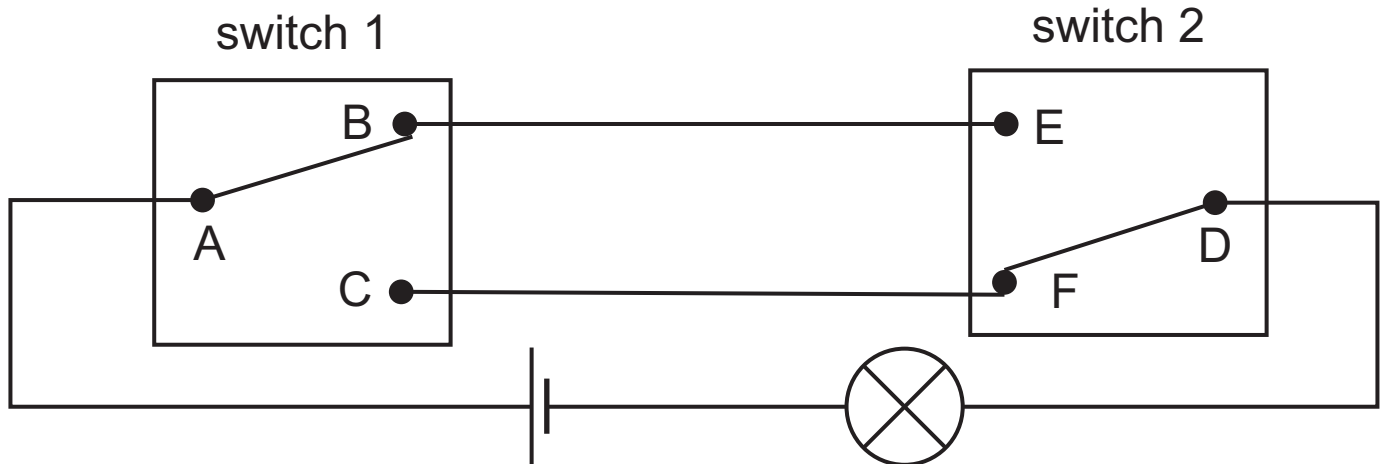

(iii) Explain why the bulb is **not** lit when the switches are in the positions shown. [1 mark]

(iv) What should happen at switch 1 so that the bulb is lit? [1 mark]

(v) As part of the safety associated with electrical appliances, the use of the correct fuse in the three-pin plug is essential.

The rating label for a toaster is shown below.

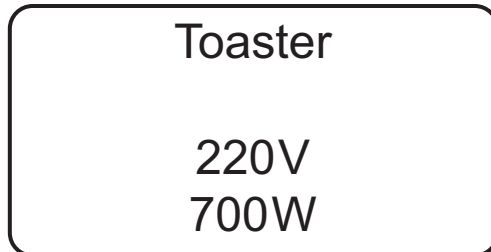

Using the information on the label, calculate the correct fuse to use. [4 marks]

The choice of fuses are 1A, 3A, 5A and 13A.

Show clearly how you get your answer, starting with the equation you plan to use.

Fuse = _____ A

(b) The circuit shown below was set up.

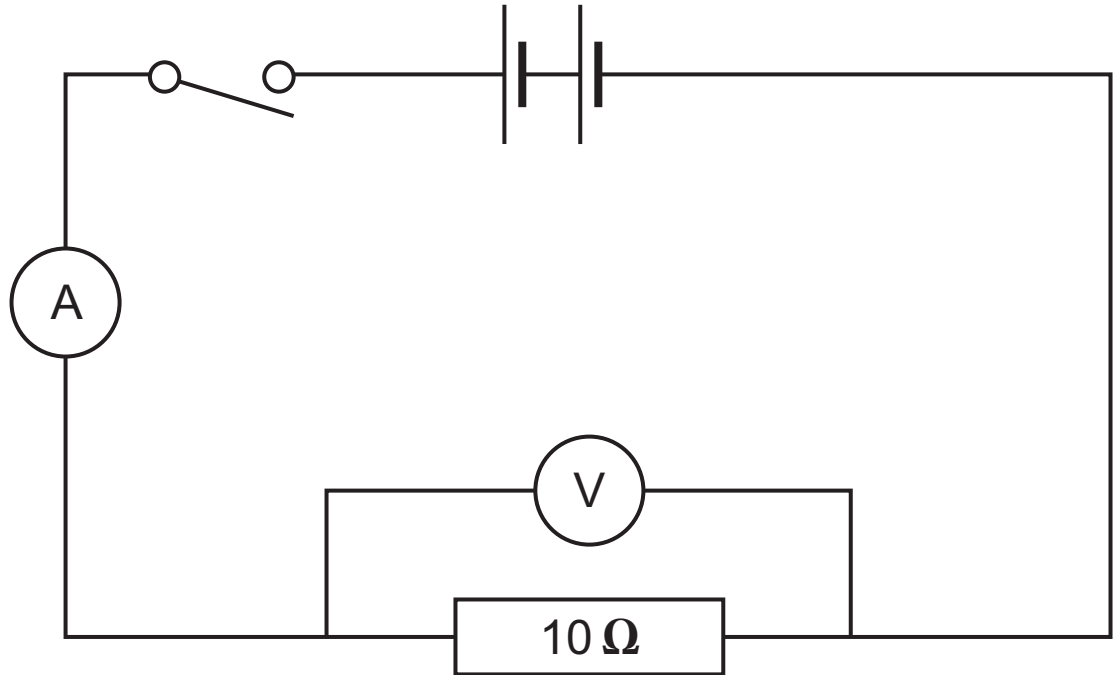

(i) When the switch is closed, the reading on the ammeter is 0.3A.

What is the reading on the voltmeter? [3 marks]

Show clearly how you get your answer, starting with the equation you plan to use.

Reading on voltmeter = _____ V

Another resistor is added to the circuit as shown below.

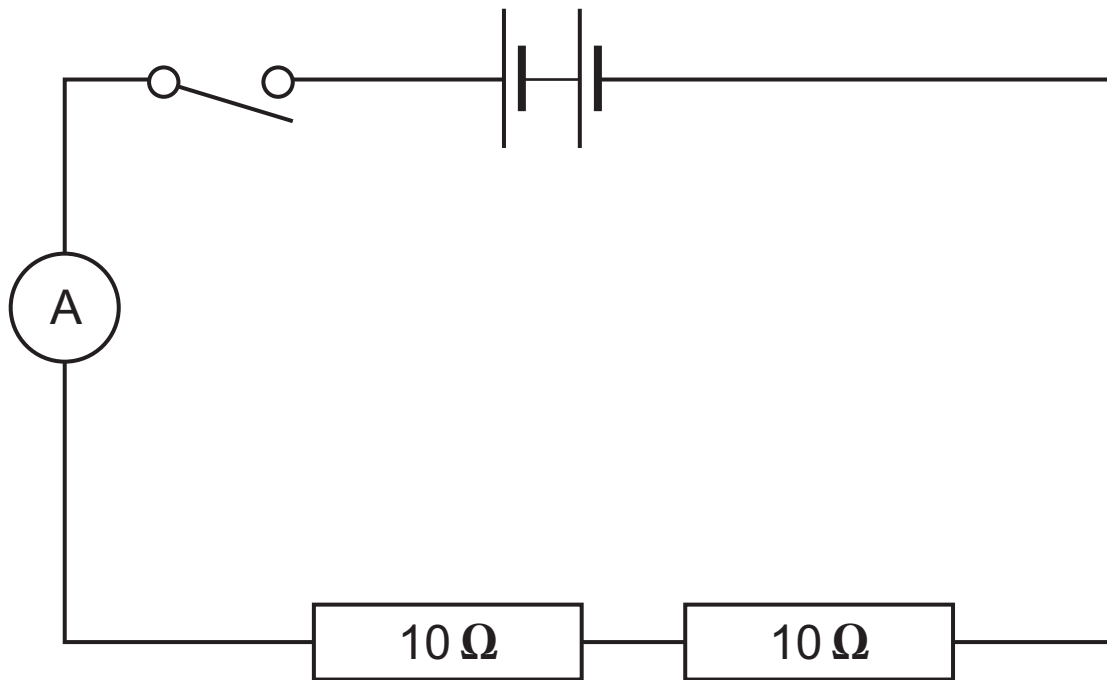

- (ii) What effect does this have on the ammeter reading?
[2 marks]
Explain your answer.

(c) (i) Two **identical** resistors are connected as shown below.

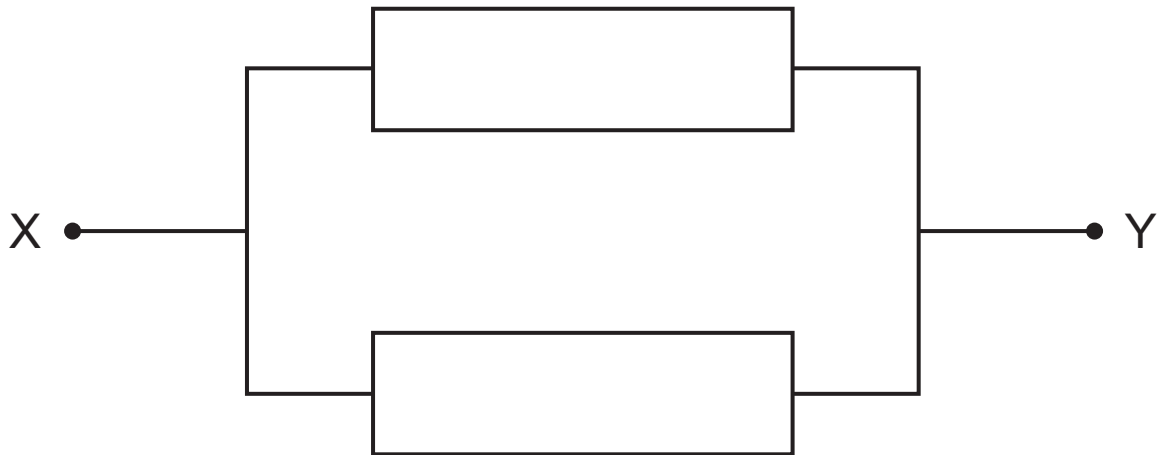

Name the type of circuit shown [1 mark]

(ii) The total resistance between X and Y is $20\ \Omega$.
Write the value of each resistor inside each symbol.
[1 mark]

(d) The circuit shown below was built using two identical bulbs.

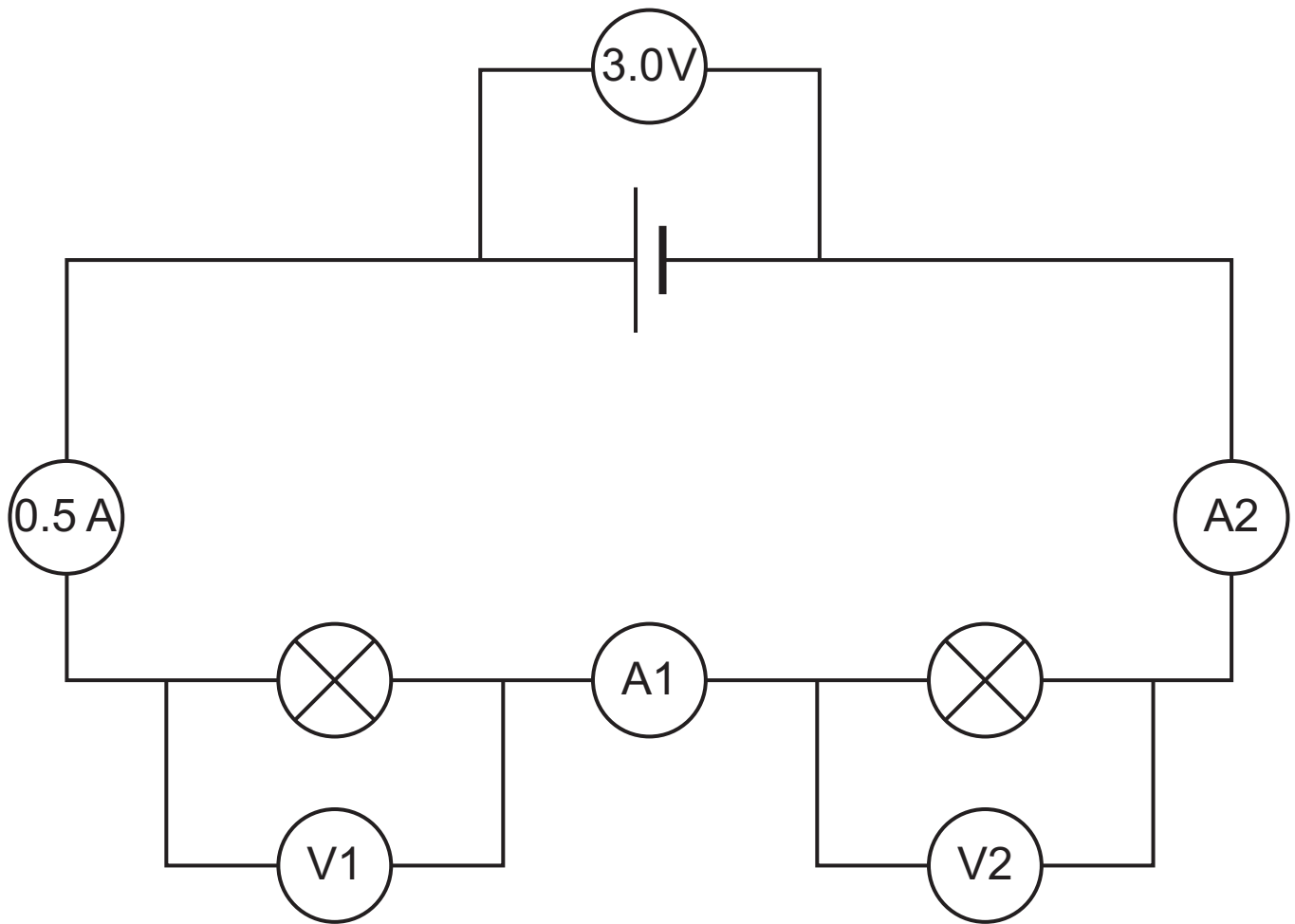

For each meter, state the reading. [2 marks]

Reading on A1 = _____

Reading on A2 = _____

Reading on V1 = _____

Reading on V2 = _____

- 4 (a) The diagram shows a coil of wire wrapped around a soft iron bar.

When a current is passed through the coil a magnetic field is created around the coil.

Label the north and south poles, using the boxes shown.

On the diagram, draw **one** magnetic field line and mark its direction. [3 marks]

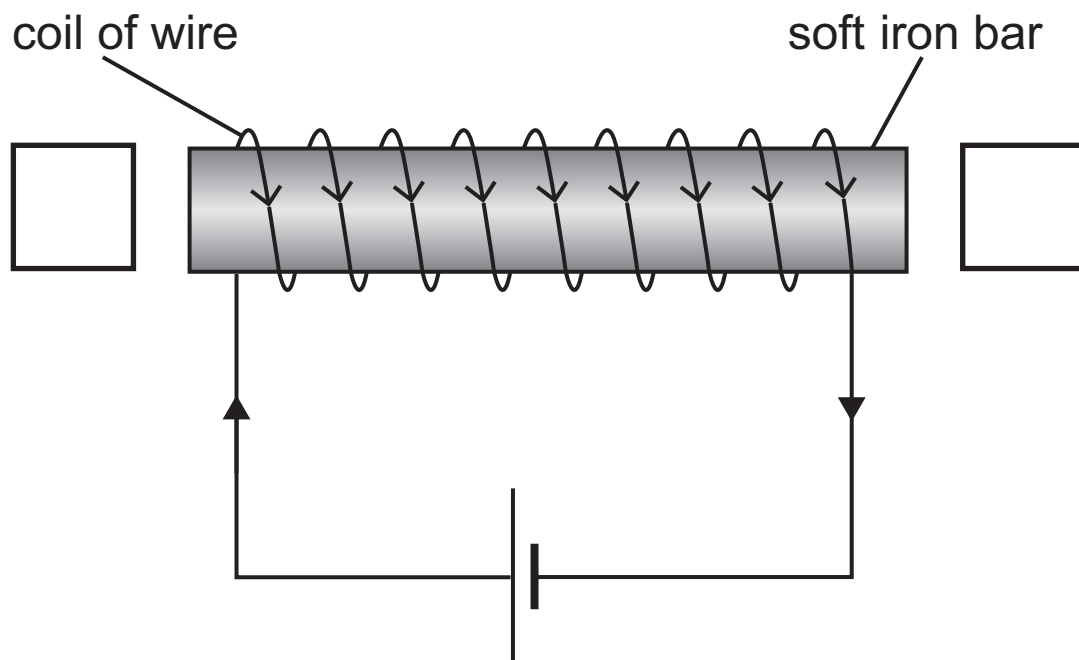

(b) The diagram below shows an a.c. generator.

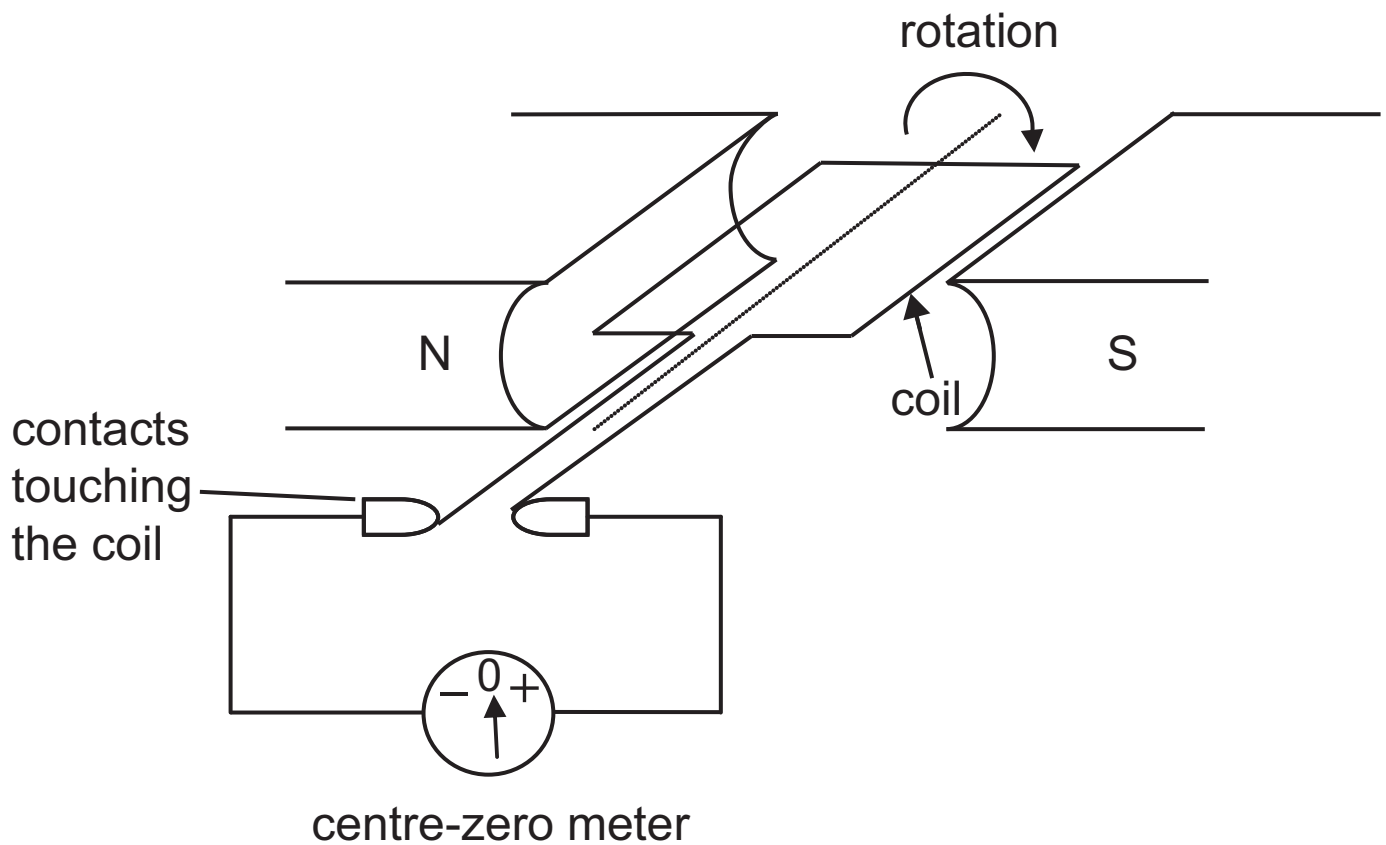

(i) State what happens in the coil of wire when it rotates between the poles of the magnet. [1 mark]

(ii) Describe carefully the motion of the pointer in the centre-zero meter when the coil is rotated continuously. [2 marks]

- (c) (i) Complete the sentences below about transformers. Choose your answers from the words and phrases in the list. [3 marks]
Each word or phrase may be used once, more than once or not at all.

isolating
step-up
increase
decrease
step-down
alternating
direct
battery

1. A _____ transformer gives a higher voltage at the secondary coil than at the primary coil.
2. The purpose of the core is to _____ the magnetic field strength between the primary and secondary coils.
3. The output voltage of a transformer is _____ .

The output from a power station is connected to a step-up transformer, which in turn is connected to the transmission lines.

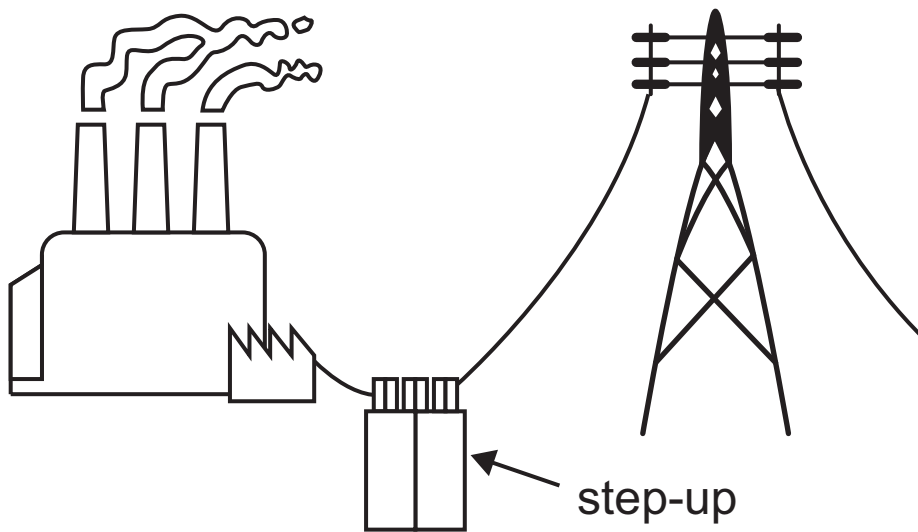

(ii) Explain the advantage of using a step-up transformer to distribute electricity. [2 marks]

5 (a) There are many different types of objects in our Solar System which can be observed from the Earth. Among them are the rocky planets and the gas planets.

(i) In the table below, place a tick (✓) in the correct box to identify which are rocky planets and which are gas planets. [2 marks]

Planet	Rocky	Gas
Neptune		
Saturn		
Earth		
Jupiter		

(ii) Write down the name of a gas planet whose name does not appear in the list above. [1 mark]

(iii) All planets orbit the Sun. What force enables this to happen? [1 mark]

(iv) Other than the Sun, planets, moons and comets, what other objects are part of our Solar System? [1 mark]

Spacecraft which orbit planets are called artificial satellites.

(v) State one use of artificial satellites which orbit the Earth. [1 mark]

(b) There are over 4000 known planets outside our Solar System. In the search for life on these planets, scientists are trying to find out the composition of the atmospheres around these planets.

(i) What gas in particular are they searching for in these planetary atmospheres? [2 marks]
Give a reason for your answer.

Gas: _____

Reason: _____

(ii) State briefly how scientists are trying to identify the gases in these planetary atmospheres. [2 marks]

This is the end of the question paper

SOURCES

Q1(d) . . . © Getty Images

Q2(a)(ii) . . . © Getty Images

Q4(a) . . . © CCEA

Q4(c)(ii) . . . Adapted from National Energy Education Development Project (Public Domain) <https://www.eia.gov/energyexplained/electricity/delivery-to-consumers.php>

For Examiner's use only	
Question Number	Marks
1	
2	
3	
4	
5	
Total Marks	

Examiner Number

Permission to reproduce all copyright material has been applied for.
In some cases, efforts to contact copyright holders may have been unsuccessful and CCEA will be happy to rectify any omissions of acknowledgement in future if notified.